

FUME AND CHEMICAL HOSE FOR TEMPERATURES UP TO +350°F

Master-Clip HYPALON®

Material

Hose wall: HYPALON®-coated polyester fabric
External helix: galvanized steel

Applications

- Air-conditioning/ventilation systems
- Automotive industry
- Engine manufacturing
- Exhaust gas extraction
- Suction of aggressive media
- Transport of hot or cold air
- Granulate drying
- Suction plants
- Standard industrial hose
- Low pressure applications

Properties

- Flame-resistant
- Improved temperature resistance
- Excellent chemical resistance
- Highly flexible
- Extreme compressibility 1:6
- Small bend radius
- Vibration-proof
- Good UV/ozone resistance
- External steel helix protects against abrasion



Construction

1. External helix
2. Hose wall: HYPALON®-coated polyester fabric

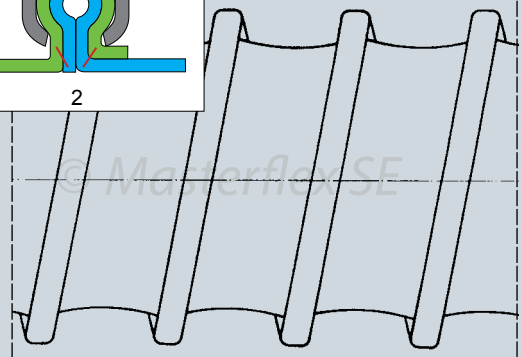
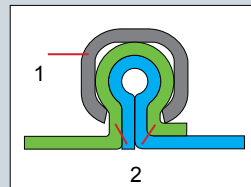

Temperature Range

- -40°F up to +350°F
- Intermittent to +375°F

Chem. Resistance

See resistance table

Master-Clip HYPALON®

Dia (in.)	Positive (in. w.c.)	Negative (in. w.c.)	*Bending radius (in.)	Weight (lbs./ft.)	Product Code
2.50	273	95	1.56	0.3355	221-063-107
3.00	249	71	1.80	0.4026	221-075-107
3.50	225	49	2.16	0.4026	221-090-107
4.00	205	40	2.40	0.4026	221-100-107
4.50	193	33	2.64	0.4697	221-115-107
5.00	133	26	3.00	0.5368	221-125-107
5.60	100	20	3.36	0.5368	221-140-107
6.00	88	18	3.60	0.6039	221-150-107
6.40	84	16	3.84	0.6039	221-160-107
7.00	74	13	4.20	0.6710	221-175-107
8.00	59	10	4.80	0.8052	221-200-107
9.00	46	8	6.32	0.9394	221-225-107
10.00	40	6	7.00	1.0736	221-250-107
11.00	32	5	7.72	1.2749	221-275-107
12.00	28	4	8.40	1.4091	221-300-107
13.00	24	4	9.12	1.4762	221-325-107
14.00	23	3	9.80	1.6775	221-350-107
15.00	20	3	10.52	1.9459	221-375-107
16.00	19	3	11.20	2.0801	221-400-107
18.00	18	2	14.40	2.4156	221-450-107
20.00	17	2	16.00	2.7511	221-500-107
22.00	17	1	17.60	3.0866	221-550-107
24.00	16	1	19.20	3.4221	221-600-107
28.00	12	1	22.40	4.0260	221-700-107
32.00	9	1	25.60	4.6299	221-800-107
36.00	6	1	28.80	5.2338	221-900-107

*Referring to the inner side of the elbow of hose.

The above mentioned data refers to an average and ambient temperature of 68o F. Subject to technical changes and color variations. Please refer to technical data sheet when selecting hose.

HYPALON® is a registered trademark of DuPont Dow Elastomers.

Installation and connection possibilities



Clip-Grip hose clamp, screwable



Hose connector



Hose reducer, symmetrical

Masterduct, Inc.
5235 Ted Street
Houston, TX 77040 USA
Tel. +1 713 462-5779
Tel. +1 800 318-3300
Fax +1 713 939-8441
www.Masterduct.com

Standard Production

- Diameter: 2.5" to 36"
- Color: outside black, inside green
- Standard lengths: 25'

Available on Request

- Special lengths
- Custom design with other pitches and helix sizes
- External helix also in stainless steel
- Electrical current filler wire
- Special diameters metric